

PRODUCT NUMBER
SEE SHEET 2

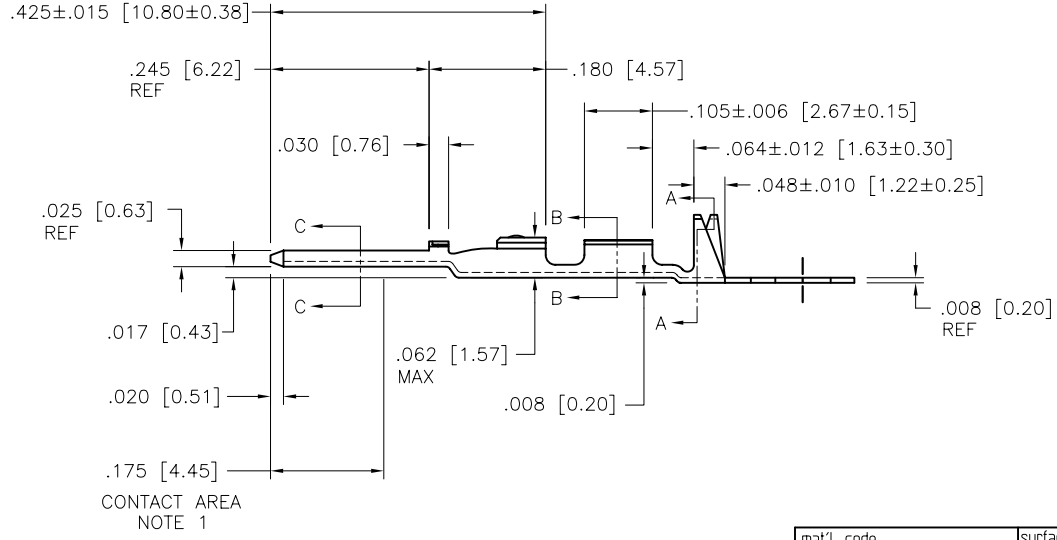

mat'l. code				surface		tolerance		projection		product family		
SEE TABLE				✓				INCH/MM		PV TERMINALS		
ltr	ec'n no	dr	date	tolerances unless otherwise specified				title		DUPLX CTW MALE PIN		
A	APPROVED	CT	1982-08-05	angles	XX+01/XX+3			scale		sheet 1 of 3 size		
B	V40928	MSC	1994-08-22		XXX+005/XXX+13			4:1		76808 A4		
C	V41706	SAR	1994-12-13	0°±2'	XXXX+0020/XXX+051					type CUSTOMER Drawing		
D	V04-1158	TAB	2004-12-06	dr	M. CLOUSER	1994-08-22		FCI				
E	V05-0281	HTB	2005-04-14	engr	T. HANNA	1994-08-22						
F	V06-0624	HTB	2006-06-30	chr	T. HANNA	1994-08-22						
G	V08-0114	HTB	2008-04-01	appd	T. HANNA	1994-08-22						
sheet	revision	G	G	G								
index	sheet	1	2	3								

PRODUCT NUMBER		LOOSE PIECE PRODUCT NUMBER	AWG	PLATING	DIM D	DIM E	DIM F	DIM G	DIM H	DIM J
RIGHT - LEFT	LEFT - RIGHT									
76808-001	76808-004	76808-007	O B S O L E T E							
76808-001LF	76808-004LF	76808-007LF	28-32	NOTE 7	.115 [2.92]	.105 [2.67]	.040 [1.02]	.058 [1.47]	.054 [1.37]	.011 [0.28]
76808-002	76808-005	76808-008	O B S O L E T E							
76808-002LF	76808-005LF	76808-008LF	22-26	NOTE 7	.139 [3.53]	.120 [3.05]	.050 [1.27]	.065 [1.65]	.070 [1.78]	.017 [0.43]
76808-003	76808-006	76808-009	O B S O L E T E							
76808-003LF	76808-006LF	76808-009LF	18-20	NOTE 7	.139 [3.53]	.120 [3.05]	.050 [1.27]	.083 [2.11]	.104 [2.64]	.021 [0.53]

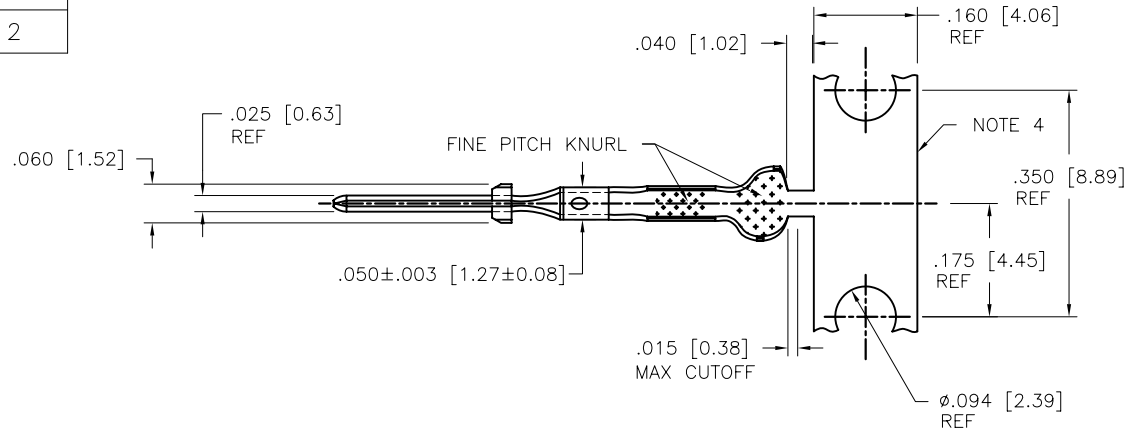
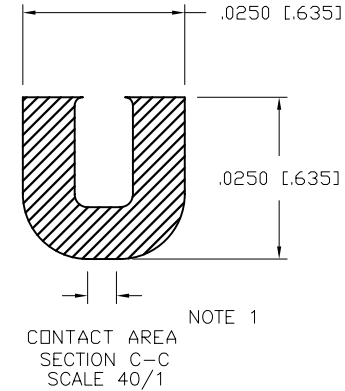
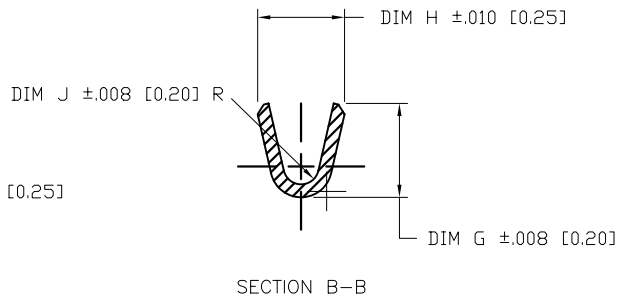
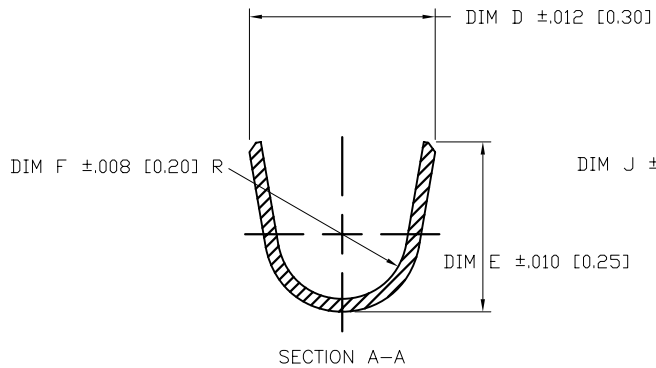

NOTES:

- ① PLATING: 50u"/1.27u MIN. Ni UNDERPLATE OVER ENTIRE TERMINAL. OVERPLATE 30u"/0.76 MIN. Au IN CONTACT AREA. 50u"/1.27u MIN. TIN-LEAD IN CRIMPING AREA.
2. TERMINAL MAY BE USED WITH MINI LATCH HOUSING.
3. APPLICABLE SPECIFICATION:
A. BUS-12-098 PRODUCT SPECIFICATION.
B. TA-211 CRIMP SPECIFICATION.
- ④ FOR MANUFACTURING PURPOSES ONLY.
- ⑤ PRODUCT MEETS EUROPEAN UNION DIRECTIVES AND OTHER COUNTRY REGULATIONS AS DESCRIBED IN GS-22-008.
6. THIS PRODUCT IS NOT INTENDED TO BE EXPOSED TO MANUFACTURING SOLDERING PROCESSES.
- ⑦ PLATING: 50u"/1.27u MIN. Ni UNDERPLATE OVER ENTIRE TERMINAL. OVERPLATE 30u"/0.76 MIN. Au IN CONTACT AREA. 50u"/1.27u MIN. TIN IN CRIMPING AREA.

mat'l. code		surface		tolerance		projection		product family	
SEE TABLE		✓		tolerances unless otherwise specified		INCH/MM		PV TERMINALS	
ltr	ecn no	dr	date	angles	inches	mm	scale	title	
				0°±2'	XXX+01/XX+3	XXX+005/XXX+13	10:1	DUPLX CTW MALE PIN	
					XXXX+0020/XXX+051			sheet 2 of 3 size	
		dr	M. CLOUSER		1994-08-22			dwg no 76808 A4	
		engr	T. HANNA		1994-08-22			FCI	
		chr	T. HANNA		1994-08-22			Type CUSTOMER Drawing	
		appd	T. HANNA		1994-08-22				
sheet index	revision sheet								

PRODUCT NUMBER
SEE SHEET 2

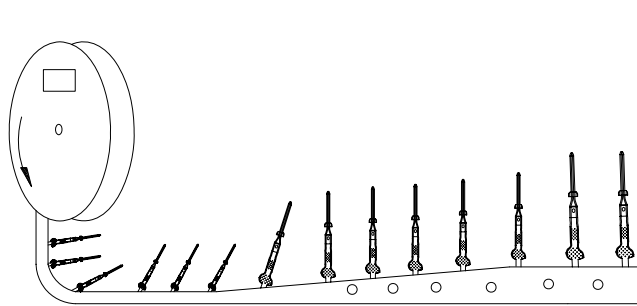

Unreeling Direction
Left to Right Into
Applicator

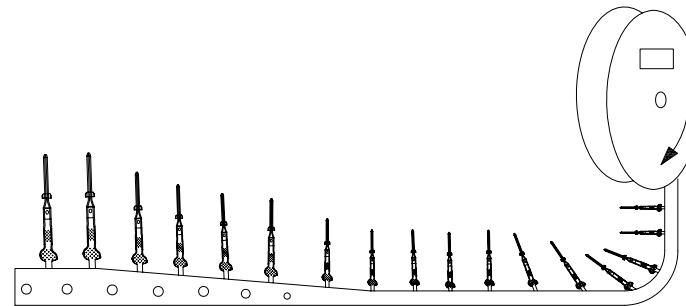

Unreeling Direction
Right to Left Into
Applicator

mat'l. code		surface		tolerance		projection		product family	
SEE TABLE						INCH/MM		PV TERMINALS	
ltr	ecn no	dr	date	tolerances unless otherwise specified		INCH/MM		title	
G				angles	.XX+01/XX+3	INCH/MM		DUPLEX CTW MALE PIN	
				linear	XXX+005/XX+13	scale 1:1		dwg no	
				0°±2'	XXXX+0020/XXX+051	FCI		sheet 3 of 3 size	
		dr	M. CLOUSER	1994-08-22				76808	
		engr	T. HANNA	1994-08-22				A4	
		chr	T. HANNA	1994-08-22				type	
		appd	T. HANNA	1994-08-22				CUSTOMER Drawing	
sheet index	revision sheet								